

STAIR PLAN AT 3RD FL.  
SCALE: 3/4" = 1'-0"  
ST1

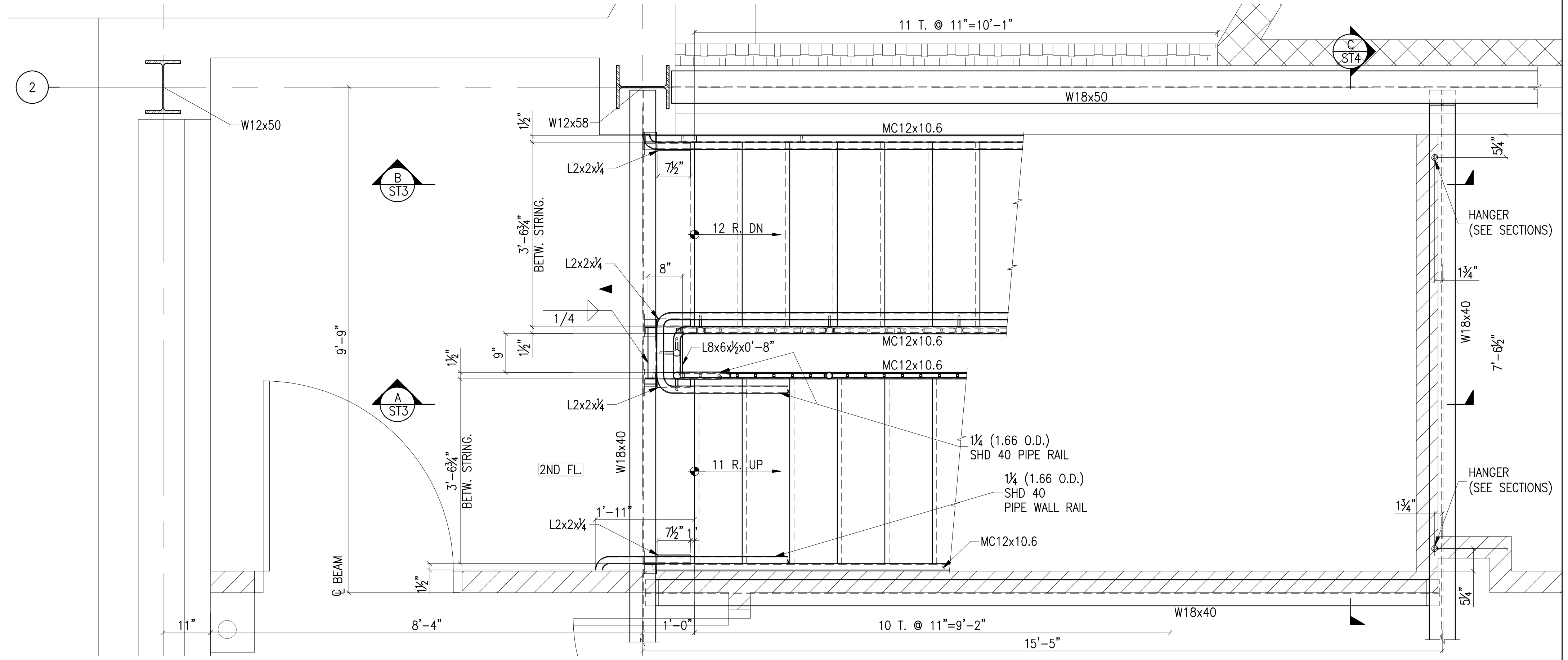

STAIR PLAN AT 2ND FL.  
SCALE: 3/4" = 1'-0"  
ST1

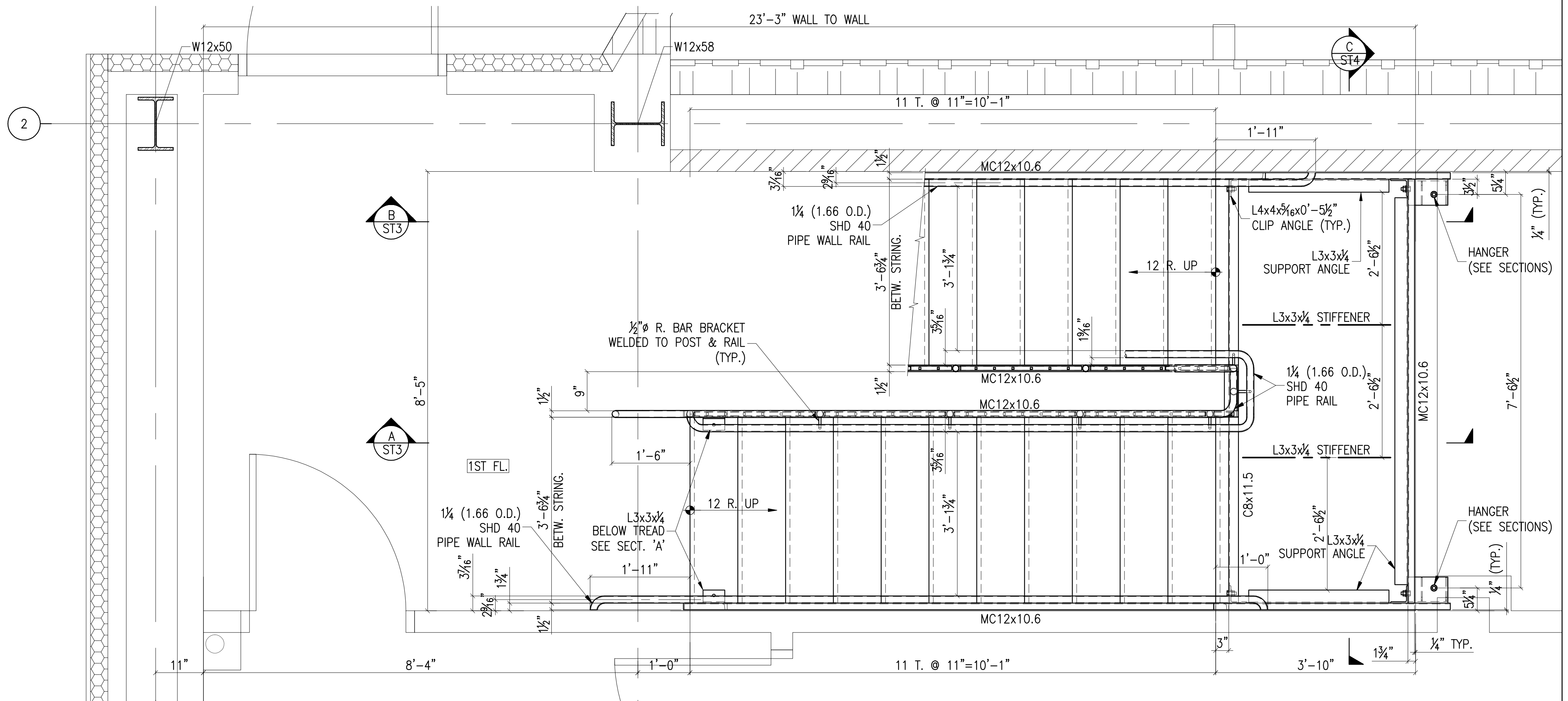

STAIR PLAN AT 1ST FL.  
SCALE: 3/4" = 1'-0"  
ST1

APPROVER:  
PLEASE VERIFY OR PROVIDE  
INFORMATION AND DIMENSIONS  
SHOWN ON THIS DRAWING

MATERIAL: A992-50; TUBES: A500 GR.B CHANNELS: A36; FITTINGS: A36 BOLTS: 3/4" A325 SC (UNO) HOLES: 13/16" (UNO) WELD: E70XX ELECTRODES LOW HYDROGEN PAINT: AS PER SPECIFICATION		<b>ELIQU &amp; SCOPELITIS STEEL FABRICATION</b> 319 FROST ST., BROOKLYN, NY 11222 Ph: (718)387-4716 Fax: (718)387-5243	
REVISIONS		PROJECT: ALBERT EINSTEIN COLLEGE OF MEDICINE TITLE: STAIR #3 1ST AND 2ND FL. PLANS LOCATION: 1510 WATERS PLACE, BRONX NY 10461	
No.	DATE	REMARKS	ENGINEER: LERA LESLIE E. ROBERTSON ASSOCIATES ARCH.: ACB ANTHONY C. BAKER, ARCHITECTS & PLANNERS, P.C. CONT.:
			DRAWN BY: A.B. DATE JOB No. DRAWING CHECKED BY: Dec/04/06

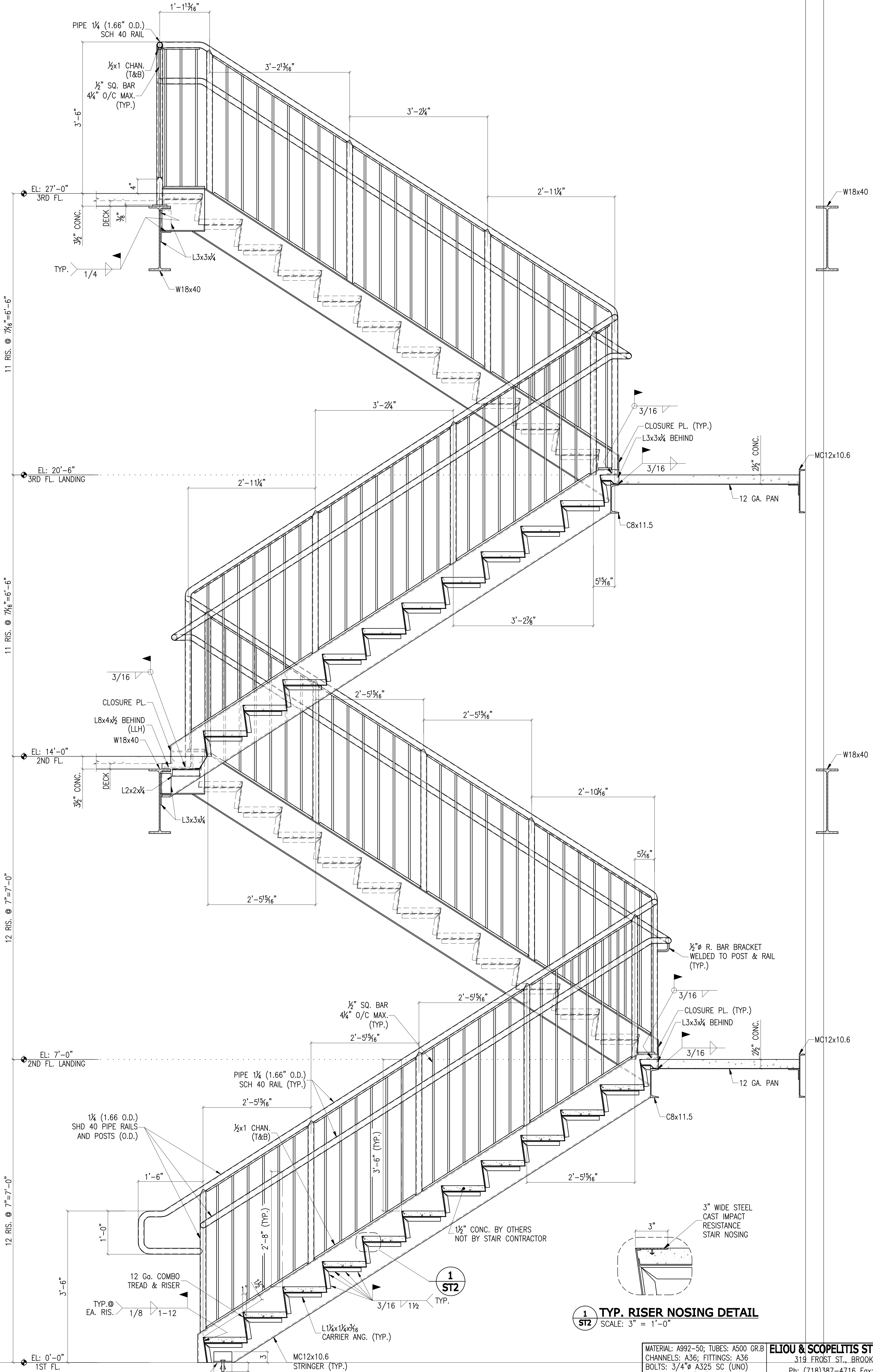

**1**  
**ST2** TYP. RISER NOSING DETAIL  
SCALE: 3" = 1'-0"

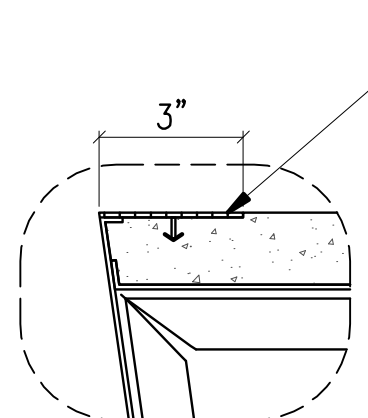

APPROVER:  
PLEASE VERIFY OR PROVIDE  
INFORMATION AND DIMENSIONS  
SHOWN ON THIS DRAWING

**A**  
**ST2** SECTION  
SCALE: 1" = 1'-0"

MATERIAL: A992-50; TUBES: A500 GR.B		<b>ELIOU &amp; SCOPELITIS STEEL FABRICATION</b>	
CHANNELS: A36; FITTINGS: A36		319 FROST ST., BROOKLYN, NY 11222	
BOLTS: 3/4" A325 SC (UNO)		Ph: (718)387-4716 Fax: (718)387-5243	
HOLES: 13/16" (UNO)		<b>PROJECT: ALBERT EINSTEIN COLLEGE OF MEDICINE</b>	
WELD: E70XX ELECTRODES LOW HYDROGEN		LOCATION: 1510 WATERS PLACE, BRONX NY 10461	
PAINT: AS PER SPECIFICATION		TITLE: STAIR #3 SECTIONS	
<b>REVISIONS</b>			
No.	DATE	REMARKS	ENGINEER: LERA LESLIE E. ROBERTSON ASSOCIATES
			ARCH.: ACB ANTHONY C. BAKER, ARCHITECTS & PLANNERS, P.C.
			CONT.:
			DRAWN BY: A.B. DATE JOB No. DRAWING
			CHECKED BY: Dec/04/06 <b>ST2</b>

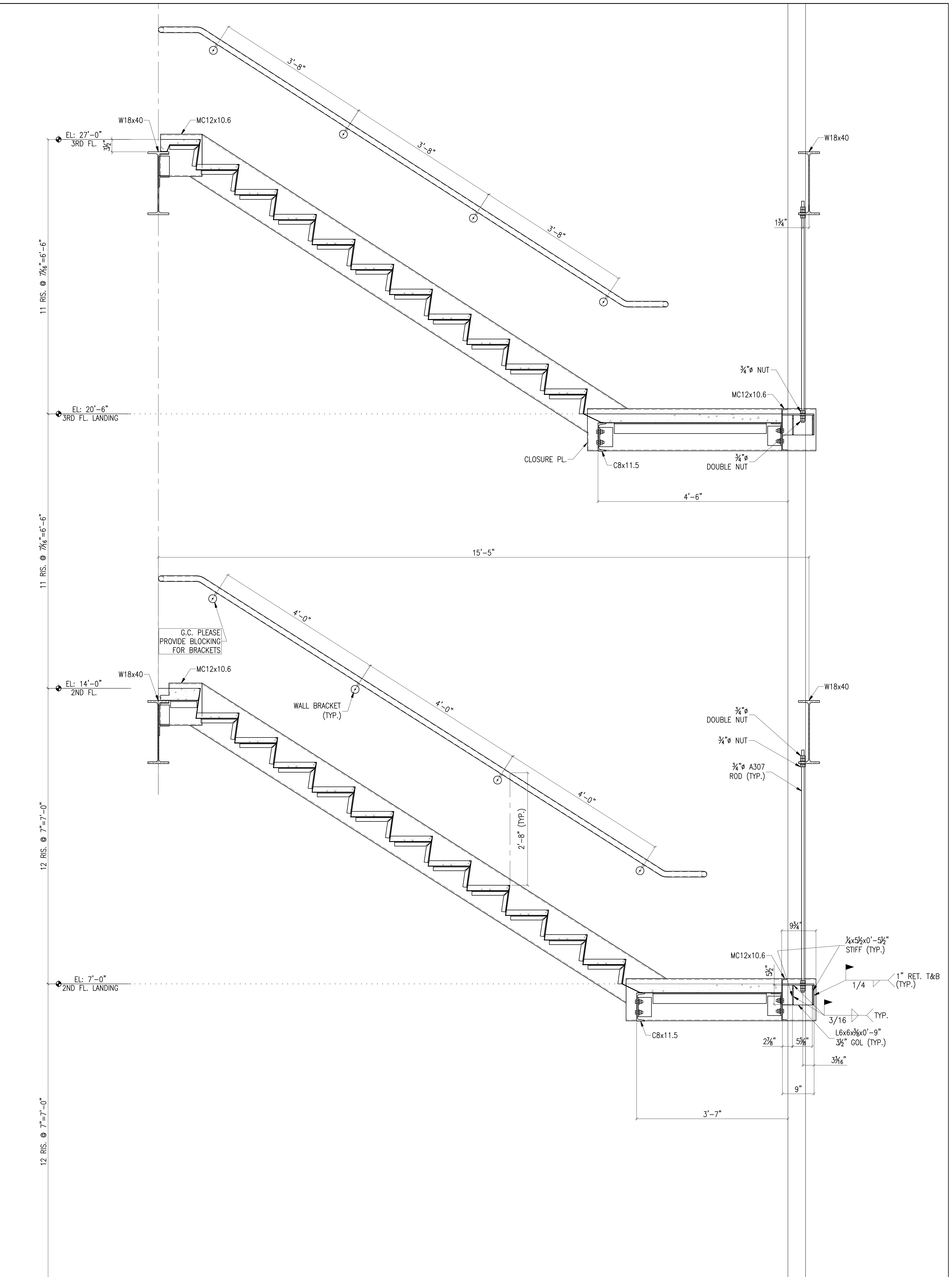

**B SECTION**  
 ST3 SCALE: 1" = 1'-0"

APPROVER:  
 PLEASE VERIFY OR PROVIDE  
 INFORMATION AND DIMENSIONS  
 SHOWN ON THIS DRAWING

MATERIAL: A992-50; TUBES: A500 GR.B CHANNELS: A36; FITTINGS: A36 BOLTS: 3/4" A325 SC (UNO) HOLES: 13/16" (UNO) WELD: E70XX ELECTRODES LOW HYDROGEN PAINT: AS PER SPECIFICATION		<b>ELIOU &amp; SCOPELITIS STEEL FABRICATION</b> 319 FROST ST., BROOKLYN, NY 11222 Ph: (718)387-4716 Fax: (718)387-5243	
<b>REVISIONS</b>		<b>PROJECT: ALBERT EINSTEIN COLLEGE OF MEDICINE</b> <b>TITLE: STAIR #3 SECTIONS</b>	
No.	DATE	REMARKS	LOCATION: 1510 WATERS PLACE, BRONX NY 10461
			ENGINEER: LERA LESLIE E. ROBERTSON ASSOCIATES
			ARCH.: ACB ANTHONY C. BAKER, ARCHITECTS & PLANNERS, P.C.
			CONT.:
			DRAWN BY: A.B. DATE JOB No. DRAWING
			CHECKED BY: Dec/04/06 <b>ST3</b>

